

14年全球  
World No.1\*

**JACK**

# Pz2 Automatic Spreader

Steady Fabric Feeding  
High Efficiency  
Wide Fabric Compatibility



\*数据来源:弗若斯特沙利文按全球各大工业缝纫机企业于2010年至2023年间每年的工业缝纫机销售台数统计,于2024年9月完成调研。  
\*Source: Frost & Sullivan's research based on the number of industrial sewing machines sold by major global industrial sewing machine companies in each year between 2010 and 2023, market research completed in September 2024.

## Hardware and software advantages



### Edge Alignment device

The optimal solution for edge curling prevention of elastic knitted fabrics



### Automatic tension regulation and precise control of tightness

Real-time detection of fabric tension, with spreading accuracy achieving errors within 1 cm at both ends and 0.5 cm at the edges. Coupled with a raising and edge-trimming device, it performs exceptionally well in handling soft, stretchy, and curling fabrics.

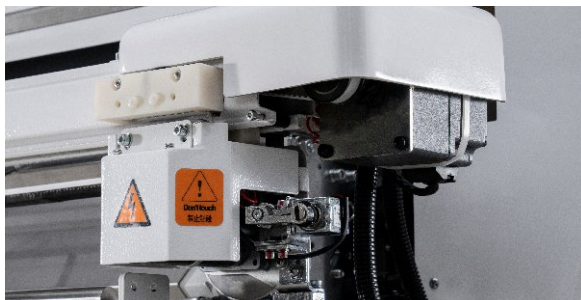

### Automatic sharpening

Automatically sharpens blades based on fabric cutting frequency, with adjustable parameters to ensure cutting quality



### Servo motor control system, Fabric Spreading Efficiency Increased by 25%

Servo core algorithm increases the spreading speed from 94 m/min to 110 m/min: The touchscreen memory function is adopted for tension adjustment, ensuring both convenience and precision. This replaces traditional mechanical tension regulation, addressing the issue of human inaccuracy

## Product parameters

单位: mm

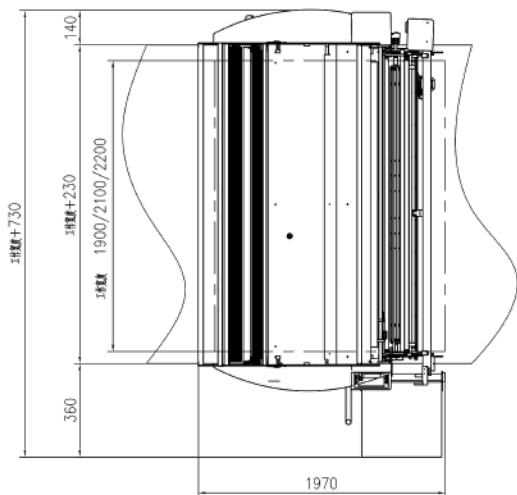

### Machine dimensions L×W×H

2330x1970x1000mm 2630x1970x1000mm  
2830x1970x1000mm 2930x1970x1000mm  
3130x1970x1000mm

### Fabric width (customizable dimensions)

1600mm 1900mm 2100mm 2200mm 2400mm

### Cutting Table Width (Customizable sizes available)

1830mm 2130mm 2330mm 2430mm 2630mm

### Laying Height

单拉: 220mm max 双拉: 150mm max

### Weight

310kg 355kg 375kg 395kg 415kg

### Net Weight / Gross Weight

425/525kg 475/580kg 495/605kg 520/635kg 545/670kg

### Maximum fabric weight

60kg max

### Maximum Cloth Diameter

450mm max

### Working voltage

AC 220V±5%

### Maximum operating speed

110m/min max